



sameyde
MANAGEMENT

5920 ENTERPRISE



LEASE OPTIONS

This 12,000 square foot building is located on Enterprise Dr.(between Aurelius Rd. and Pennsylvania Ave.) Close proximity to 127 and 96 freeways on Lansing's south side.

BUILDING HIGHLIGHTS

- Large Parking Area
- Fire Sprinkler System
- Light Industrial Zoning
- Office Zoning



5918 LOCATION

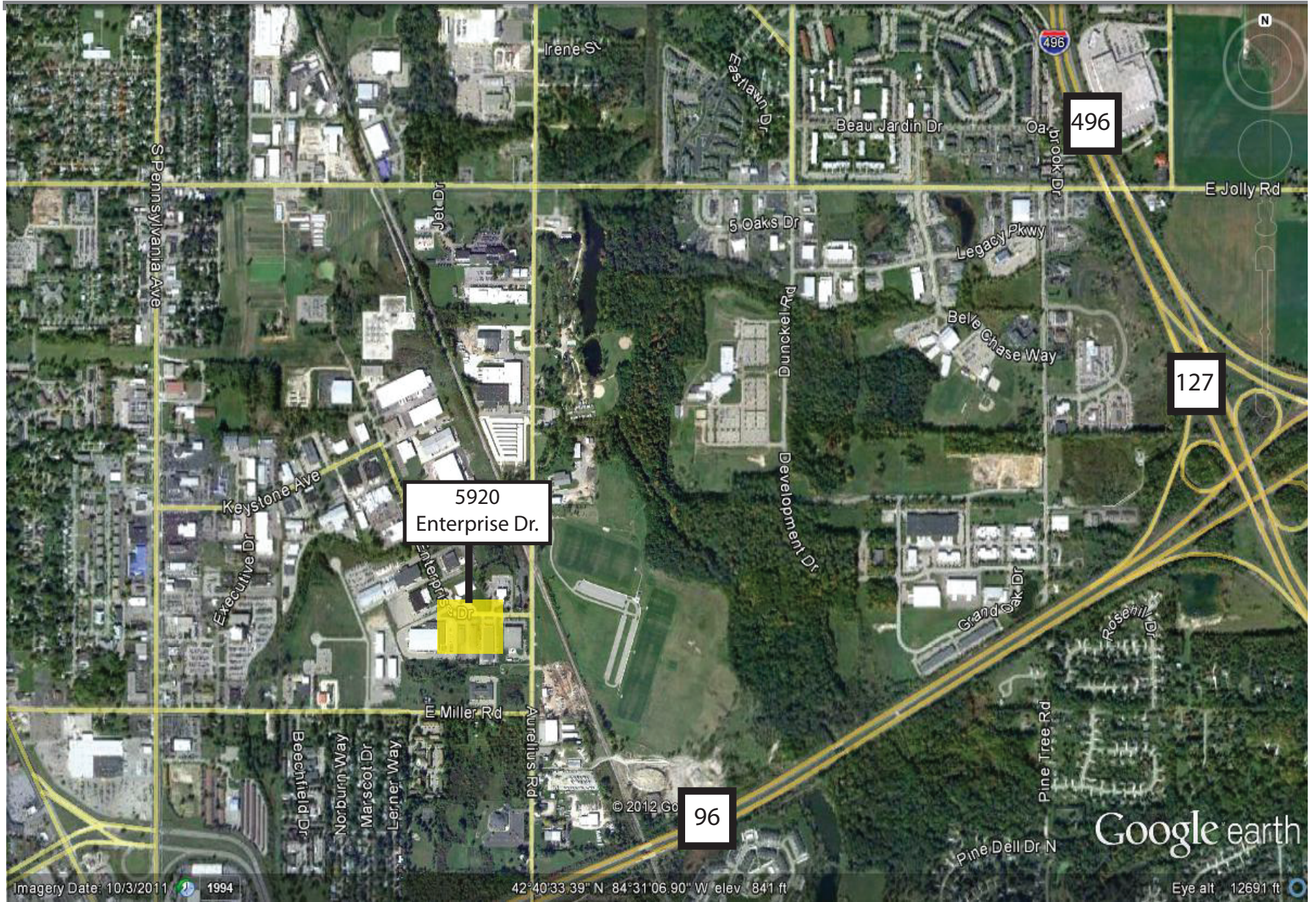



sam
eyde
MANAGEMENT

5920 FLOOR PLAN

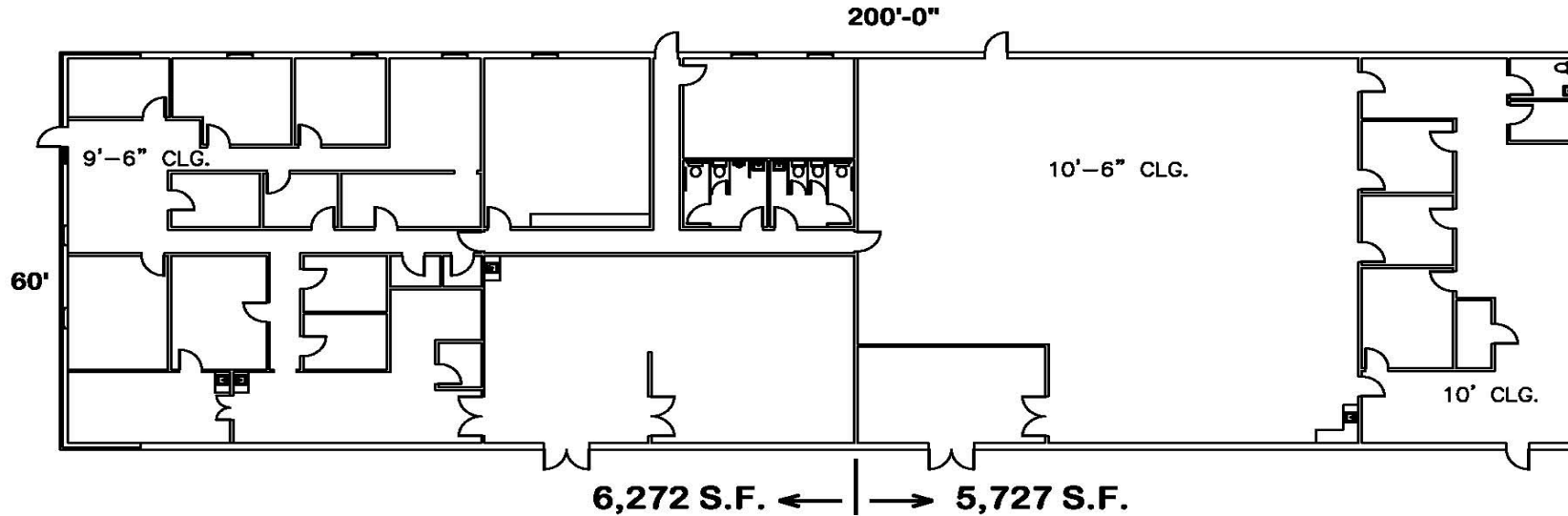

 **EXISTING FLOOR PLAN**
NOT TO SCALE

**SAM
EYDE**
MANAGEMENT

2801 OODIDGE
SUITE 501
EAST LANSING, MI 48823
PHONE: 517.333.3430
FAX: 517.333.6725

EXHIBIT A.1

5918
ENTERPRISE
DRIVE

LANSING
MICHIGAN
48911

EXISTING
FLOOR PLAN

DATE: 7/27/06

DR. BY: CJR

SCALE: None